

**MTY-0,5M****MTY-1,5M****MTY-2,5M****MTY-4M****MTY-0,5MF****MTY-1,5MF****MTY-2,5MF****TECHNICAL DETAILS**

- Voltage 230V
- Standard dimensions MTY-MF (mm) : 82x82x61
- Standard dimensions MTY-M (mm) : 82x82x70
- Indicator lamp
- Fuse protection

	MTY-0,5M/MF	MTY-1,5M/MF	MTY-2,5M/MF	MTY-4M
INTENSITY	0,5A	1,5A	2,5A	4A
MINIMUM REGULATION INTENSITY	0,1A	0,15A	0,25A	0,4A
FUSE	630mA	1,5A	2,5A	4A

**INSTRUCTIONS FOR BUILT-IN ASSEMBLY (IP44)**

MTY-4M is only available for surface assembly.

Using a small screwdriver remove the start button ❶, with a full turn clockwise it can be taken off very easily.

After removing the hexagonal nut, remove the cover. Connect the regulator as shown in the sketch.

Connect to the mains and adjust the minimum motor speed using ❷.

Put on the cover and close the joint.

Firmly adjust the start button ❶ and put in the STOP position.

**INSTRUCTIONS FOR SURFACE ASSEMBLY (IP44)**

Follow the instructions given for built-in assembly.

The regulator can be fixed to the box with the 2 screws supplied.

Do not use the joint. In very damp conditions a hole of 5mm must be made in the bottom of the box to allow for condensation (see figure).

**ADJUSTING THE MINIMUM SPEED**

The minimum speed ❷ must be adjusted so that the motor will start even at this speed.

**ELECTRIC MOTORS**

The regulator can only be applied to electric motors prepared for speed adjustment. Each motor must be thermally protected.

**CHANGING THE FUSE**

Dismantle the regulator as indicated in the assembly section. Lift the fuse box ❷ (containing 1 reserve) with a small screwdriver. Put in the reserve fuse. Reassemble as indicated above.

**N.B.**

The supply to the regulator and the output to the fans must have the appropriate section for the maximum regulator intensity, and the installation in general must presents standards.

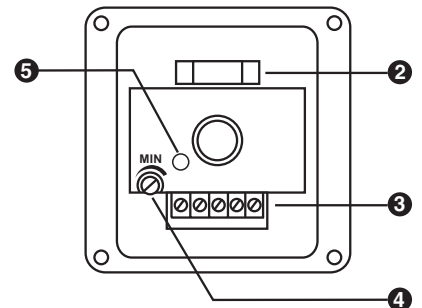
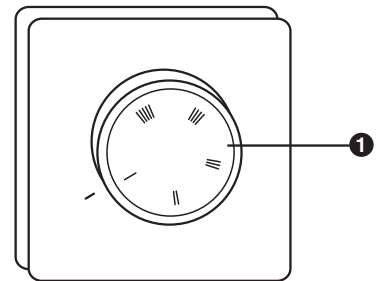

- ❶ - Start button
- ❷ - Fuse box
- ❸ - Connection terminals
- ❹ - Minimum speed adjustment
- ❺ - Indicator led

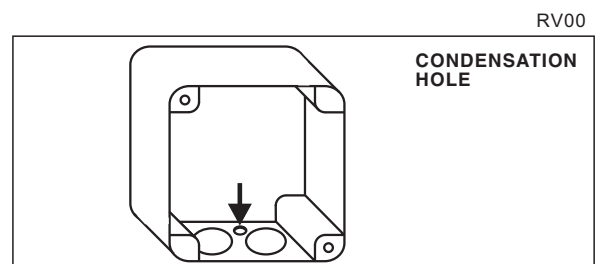
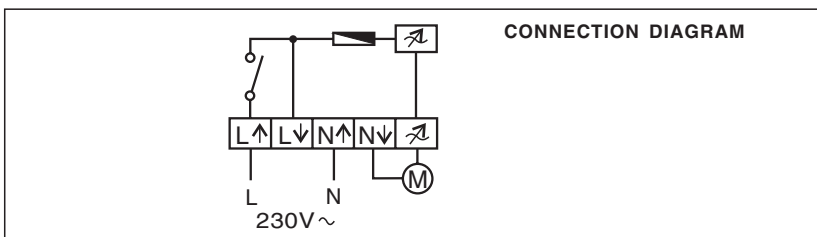

RV00