



Roof fans

Tourelles

Dachventilatoren

Крышные вентиляторы



Roof fans with horizontal discharge are used to extract air from different premises. Easy access to clean an impeller. Not suitable for polluted air, aggressive and explosive gases.

Impeller with backward curved blades.

Motor: external rotor, motor protection built-in thermal contact, maintenance free ball bearings.

Housing: powder coated painting RAL 9005.



Dachventilatoren, für Abluft bestimmt. Nicht geeignet für die Beförderung von verschmutzter Luft, aggressiven, explosiven Gasen. Laufrad ist rückwärts gekrümmt.

Der Motor: Außenrotor, integrierter Thermokontakt-Motorschutz, dauerhafte, keine Pflege erfordernde Lager.

Das Gehäuse: RAL 9005, gestrichen.



Tourelles destinées à l'extraction d'air vicié. Elles ne sont pas adaptées à l'extraction d'air fortement pollué, de gaz agressifs ou explosifs. Turbine à réaction (pales incurvées vers l'arrière).

Moteur à rotor externe, entraînement direct avec protection thermique intégrée (PTO), roulements graissées à vie ne nécessitant pas d'entretien.

Enveloppe : Finition RAL 9005.



Крышные вентиляторы для вытяжки воздуха. Не используются при транспортировке загрязнённого воздуха, агрессивных, взрывоопасных газов.

Крыльчатка: загнутые назад лопатки.

Двигатель: наружный ротор, встроенная термодатная защита двигателя, не требующие ухода подшипники с длительным сроком службы.

Корпус: окрашенный RAL 9005.

Accessories

Single phase speed controller



TGRV

p. 84

Monophase speed controller



MTY

p. 87

Curb skirt



SSA

p. 94

Curb skirt



SSA 45

p. 94

Roof curb



KSV

p. 91

Flange-adapter



FSV

p. 100

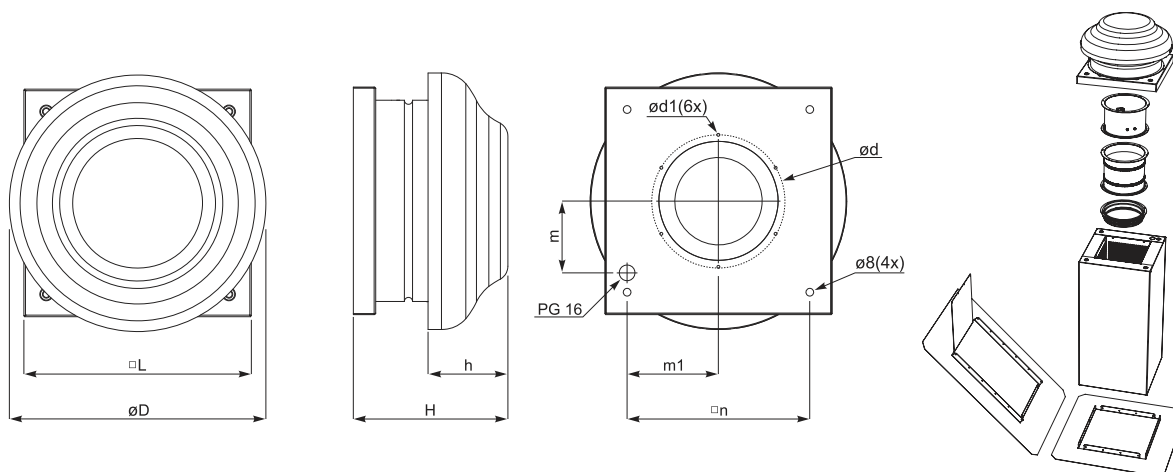

Type	Dimensions [mm]								
	ϕD	H	h	$\square L$	ϕd	$\phi d1$	m	m1	$\square n$
VSA 190S	344	207,3	107	305	177	6,1	96,5	123,5	245
VSA 190L	344	207,3	107	305	177	6,1	96,5	123,5	245
VSA 220S	450	214,35	109	405	230	7,1	138	168	330
VSA 220M	450	214,35	109	405	230	7,1	138	168	330
VSA 225L	450	245,55	109	405	230	7,1	138	168	330
VSA 250L	450	245,55	109	405	230	7,1	138	168	330

Type	Accessories							
	TGRV	MTY	SSA	SSA 45	KSV	FSV	ATS	LSV
VSA 190S	1,5	0,5	300	300	300/600	160	190	160
VSA 190L	1,5	0,5	300	300	300/800 300/900			
VSA 220S	1,5	0,5	400	400	400/600	250	250	250
VSA 220M	1,5	0,5	400	400	400/800	250	250	250
VSA 225L	1,5	1,5	400	400	400/900	250	250	250
VSA 250L	1,5	1,5	400	400	400/1000	250	250	250

Accessories

Back draft shutter

Flexible connection



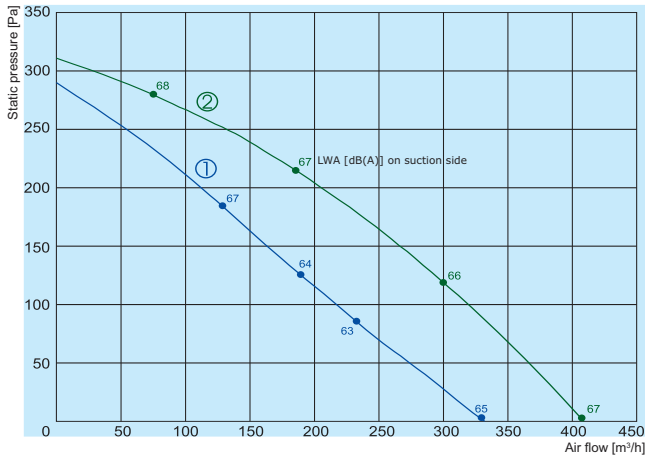

① — VSA 190 S
 ② — VSA 190 L

		VSA 190 S	VSA 190 L
Voltage/Frequency	[V/Hz]	230/50	230/50
Power consumption	[kW]	0,044	0,065
Current	[A]	0,19	0,28
Speed	[min ⁻¹]	1962	2442
Max. airflow	[m³/h]	332	409
Max. air temperature	[°C]	50	50
Weight	[kg]	4,4	4,4
Wiring diagram		No. 3	No. 2
Protection class:	motor	IP-44	IP-44
	terminal box	IP-54	IP-54

190 S

	L _{pa} dB(A)	L _{wa} total dB(A)	L _{wa} , dB(A)								
			63 Hz	125 Hz	250 Hz	500 Hz	1 kHz	2 kHz	4 kHz	8 kHz	16 kHz
Inlet	56	63	38	43	51	53	57	54	48	41	28
Outlet at 1 m dist.	55	63	36	44	53	51	53	52	48	38	25

Measured at 233 m³/h, 85 Pa

190 L

	L _{pa} dB(A)	L _{wa} total dB(A)	L _{wa} , dB(A)								
			63 Hz	125 Hz	250 Hz	500 Hz	1 kHz	2 kHz	4 kHz	8 kHz	16 kHz
Inlet	59	66	38	44	54	59	60	61	57	41	28
Outlet at 1 m dist.	53	60	28	37	51	54	58	53	47	32	18

Measured at 278 m³/h, 140 Pa

The fan characteristic curves were determined in accordance with DIN 24163 resp. ISO 5801. The sound levels were determined in accordance with DIN 45635 resp. ISO 3744 at a distance of 1 m from the fan

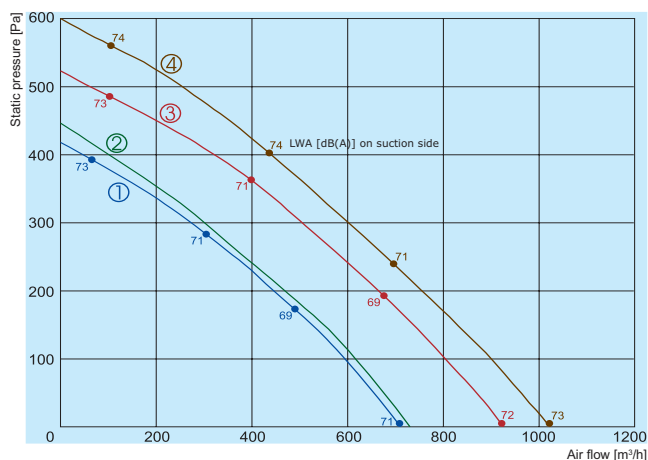

- ① VSA 220 S
- ② VSA 220 M
- ③ VSA 225 L
- ④ VSA 250 L

		VSA 220 S	VSA 220 M	VSA 225 L	VSA 250 L
Voltage/Frequency	[V/Hz]	230/50	230/50	230/50	230/50
Power consumption	[kW]	0,097	0,106	0,155	0,208
Current	[A]	0,42	0,46	0,68	0,90
Speed	[min ⁻¹]	2534	2700	2542	2442
Max. airflow	[m³/h]	711	730	926	1024
Max. air temperature	[°C]	40	55	60	40
Weight	[kg]	6,8	7,0	7,6	8,0
Wiring diagram		No. 2	No. 1	No. 2	No. 2
Protection class:	motor	IP-44	IP-44	IP-44	IP-44
	terminal box	IP-54	IP-54	IP-54	IP-54

220 S

	Lpa dB(A)	Lwa total dB(A)	Lwa, dB(A)								
			63 Hz	125 Hz	250 Hz	500 Hz	1 kHz	2 kHz	4 kHz	8 kHz	16 kHz
Inlet	62	69	39	50	57	63	64	62	58	54	34
Outlet at 1 m dist.	55	62	31	44	53	57	58	54	50	40	23

Measured at 489 m³/h, 173 Pa

220 M

	Lpa dB(A)	Lwa total dB(A)	Lwa, dB(A)								
			100 Hz	125 Hz	250 Hz	500 Hz	1 kHz	2,5 kHz	5 kHz	8 kHz	16 kHz
Inlet	64	71	42	55	58	65	65	63	60	55	38
Outlet at 1 m dist.	59	66	34	46	54	58	62	56	52	44	33

Measured at 508 m³/h, 177 Pa

225 L

	Lpa dB(A)	Lwa total dB(A)	Lwa, dB(A)								
			63 Hz	125 Hz	250 Hz	500 Hz	1 kHz	2 kHz	4 kHz	8 kHz	16 kHz
Inlet	62	69	40	52	56	63	64	62	56	51	33
Outlet at 1 m dist.	57	64	32	44	53	58	61	59	52	43	30

Measured at 585 m³/h, 251 Pa

250 L

	Lpa dB(A)	Lwa total dB(A)	Lwa, dB(A)								
			63 Hz	125 Hz	250 Hz	500 Hz	1 kHz	2 kHz	4 kHz	8 kHz	16 kHz
Inlet	64	71	44	57	59	64	65	63	62	57	44
Outlet at 1 m dist.	58	65	34	50	55	58	61	59	52	45	33

Measured at 696 m³/h, 240 Pa

The fan characteristic curves were determined in accordance with DIN 24163 resp. ISO 5801. The sound levels were determined in accordance with DIN 45635 resp. ISO 3744 at a distance of 1 m from the fan

The company reserves the right to make changes of technical data without prior notice

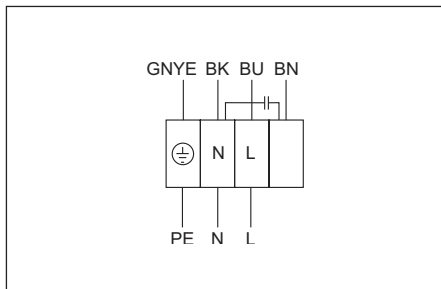

Wiring diagram No. 1 (1~230V)

GNYE - green-yellow
BK - black
BU - blue
BN - brown

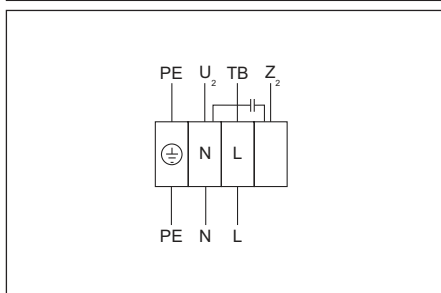

Wiring diagram No. 2 (1~230V)

U₂ - blue or grey
Z₂ - black
TB - brown
PE - yellow-green

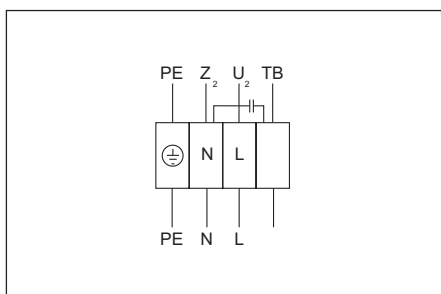

Wiring diagram No. 3 (1~230V)

U₂ - blue or grey
Z₂ - black
TB - brown
PE - yellow-green